



HIGH PERFORMANCE ELECTRONIC HEALTH RECORD (EHR) IN DIABETES FOR COUNTRIES IN BLACK SEA REGION

PART 2 – FUNCTIONS IMPLEMENTATION

Simion PRUNĂ¹, Cristina PURTILL¹, M. MATEESCU² and Constantin IONESCU-TÎRGOVIȘTE³

¹ SMEfunding Ltd, Dublin, Ireland

² Cabinet of Family Doctor, Bucharest, Sector 2, Romania

³ National Institute of Diabetes, Nutrition and Metabolic Diseases, “N. Paulescu” Bucharest, Romania

Corresponding author: Simion Pruna,

E-mail: simion.pruna@gmail.com

Accepted April 25, 2017

We developed an electronic health record (EHR) diabetes register in which over 50 process and outcome variables related to the diabetes care can be collected. Our tool envisages common set data collections in diabetes in 12 countries in Black Sea are for tracking the progression of the disease as well as for epidemiological and clinical research. The system has a number of individual application/functions being serviced by a layer database of relational tables of the relational database management system (RDBMS) that stores patient's details, clinical measurements, doctors and users' information – the persons involved in the direct or indirect provision of healthcare services to an individual or to patients' population. The privacy and data security issues are very well addressed according the existing EU legislation. A particular focus on BSTD register development was the user-friendliness and its interoperability with other systems and networks.

Keywords: Diabetes Mellitus; electronic health record (EHR); machine learning; data security; legal aspects; privacy.

INTRODUCTION

Diabetes is now a pandemic disease with negative impact on the sustainability of public health care systems and a major medical burden mainly for low income countries as are majority of countries in the Black Sea area. Despite remarkable progress in the management of diabetes chronic complications, major unmet needs remain in terms of effectiveness of prevention interventions. Electronic health records (EHRs) systems are useful tools for clinical care of patients, in tracking the progression of the disease as well as for epidemiological and clinical research.

In order to design and trigger the appropriate interventions in the DM patient's care, there are diabetes centers and specialized diabetes hospitals in Europe (*e.g.* in Denmark) which regularly record patients' data from points of care. These specialized databases are the primary source of data used by researchers and policy makers to estimate

prevalence rates of adequate versus inadequate health care management in addressing diabetes complications issues. For example, Rasmussen and colleagues published recently a paper¹ by analyzing the routinely electronic collected data at the level of clinical interaction with both Type 1 and Type 2 patients to assess diabetic foot ulcer (DFU) over a period of 14 years (2001–2014). According to the authors of this paper, patients were stratified according to etiology: neuropathic, neuro-ischemic or ischemic. The relevant conclusion, which is very convincingly integrated with the main role of regularly EHR of patients, is that the DFU incidence has decreased substantially in T1DM as well as in T2DM driven by a decrease in incidence of neuropathic ulcers. This example may be useful to illustrate the role of EHRs, respectively diabetes registers, in diabetes.

The main aim of this second part of our paper is to describe the key components of the BSTD system related with the functionality of the system to integrate a variety of heterogeneous sources of clinical data in diabetes care in primary care and in

diabetes centers e.g. in ambulatory diabetes patients and in specialized diabetes hospitals. The system concept is based on a clear identification of the state-of-the-art related to EHR approaches and standards, key technologies and design approaches (e.g. legal and security challenges that should be considered before using EHRs). This part 2 of the paper envisions describing the development of the main functions of the BSTD electronic patients' record system to register patient's structured and unstructured data for the clinic use in diabetes both in primary care and in diabetes centers and specialized diabetes hospitals. Our paper may be helpful for development diabetes register based on information and communication technologies that currently are implemented in medical informatics such as shared electronic cooperation platforms.

PHYSICIANS SUPPORT

In order to match the local clinic workflow with the usability of the BSTD registry system, the support physicians/nurses and GPs were involved in both the design and development phases. They contributed with professional comments and suggestions for improving the functionality of the system through frequent users' feedback allowing for adaptation usability or changing requirements throughout the process of the project implementation. In the development phase the software components were need to undergo regular evaluations performed by the end users and iterative improvements in order to satisfy the user requirements. Therefore, usability is guaranteed because BSTD contains a set of functions around EHRs of a patient based on general concepts for efficient strategies of diabetes register development that combine a high level of functionality and utility with user-friendly and consistent user-interface.

The main aims at designing and developing BSTD framework were to support efficient clinical practice through innovative medical informatics technological tools for more efficient health care (e.g. rapid access to information, to clinical protocols, to statistical reports, etc.) and a well-established informatics engineering contribution to build "controllers" (e.g. statistical analysis and associated graphics) to guide diabetes care to higher quality.

Diabetic patients' interaction with the GP (family doctor): BSTD includes practical applications to be implemented as a reliable efficient medical informatics platform and management system for electronic health record

(EHR) – based decision support in primary care of diabetes. Literature search² indicates that the primary care EHR data provides clear and very good benefits to the prospective surveillance of incidence and prevalence of type 2 diabetes^{3,4}. For example, BSTD is well suited for electronic patients recording in prediabetes screening and on epidemiological studies in detection of previously undiagnosed Type 2 diabetes cases. The potential impact of the outcomes of the implementation of a policy for systematic dysglycemia screening including formal training and EHR templates in primary care clinics is illustrated in a published paper in *Diabetes Care*, 2017⁵. Using the BSTD system there is a clear advantage to the primary care as a diabetes register because A1c, blood pressure, lipids, hypertension, smoking, obesity, etc. are parameters that can be recorded into our system. They are EHRs parameters that validate diabetes, hyperlipidemia, hypertension diagnosis in primary care. BSTD diabetes register was extensively tested in practice and it proved to be a valid EHRs source for epidemiological surveillance and quality care monitoring in Black Sea area population. In addition, the relevant research results show that electronic diabetes registries offer many benefits over paper-based registries, such as quality data validation.

DATASET SELECTION

The first step in implementation the BSTD project we had to address the necessary data sets to develop an international electronic health data record system in Black Sea area. This was the central aspect to this project for care diabetes management which includes also targeted guidelines (e.g. clinical protocols). However, we have observed that protocols and methods to collect data are different without taking into account ontologies and standardizations, and so such heterogeneous information cannot be integrated to make comparative epidemiological studies in Black Sea area. The lack of standardization of data definition was the essential drawbacks of the approach of routinely collection of hospital admission data at the beginning of 1990s decade for the measurement of the outcome indicators in diabetes services⁶. Therefore, aiming to address this issue of lack of consensus in diabetes care quality assessment, the WHO/Europe (Quality of Health Systems) has initiated the development (through a formal consensus process) of a common diabetes dataset entitled, "DIABCARE". Fields and definitions of DIABCARE have been agreed to

allow common monitoring of diabetes throughout Europe. Data parameters and definitions of DIABCARE (e.g. patient demographics, risk

factors, intermediate outcomes)^{7,8,9,10,11} have been agreed at European level to allow common monitoring of diabetes throughout Europe^{12,13}.

DIABCARE

Basic Information Sheet
Implementation of the St. Vincent Declaration



Internat. Centre: _____

Basic Patient Data	N°: _____	Initials _____	Month _____	Year _____	Sex <input type="checkbox"/> M <input type="checkbox"/> F
	IDDM <input type="checkbox"/> NIDDM <input type="checkbox"/> Other <input type="checkbox"/>	first n. last n. Diabetes since: 1 9	DOB: _____	OAD since: 1 9	Insulin since: 1 9

Reasons for Consultation/ Admission	Consultation or: Admission <input type="checkbox"/>	Routine visit Newly diagnosed <input type="checkbox"/>	Stabilisation Pregnancy <input type="checkbox"/>	Complications Emergency <input type="checkbox"/>	Other <input type="checkbox"/>
--	---	--	--	--	--------------------------------

Pregnancies	ending within last 12 months <input type="checkbox"/> Y <input type="checkbox"/> N	Normal <input type="checkbox"/>	Abortions <input type="checkbox"/>	Major malformations <input type="checkbox"/>	Perinatal deaths <input type="checkbox"/>
--------------------	--	---------------------------------	------------------------------------	--	---

Risk Factors current status	Smoker <input type="checkbox"/> Y <input type="checkbox"/> N	IF YES: cig./day _____	Alcohol <input type="checkbox"/> Y <input type="checkbox"/> N	IF YES: g/wk _____
------------------------------------	--	------------------------	---	--------------------

Self-Monitoring	Self-monitoring <input type="checkbox"/> Y <input type="checkbox"/> N	Blood glucose/wk _____	Urine glucose/wk _____
------------------------	---	------------------------	------------------------

Education/ Diab. Pat. Org.	Healthy eating <input type="checkbox"/> Y <input type="checkbox"/> N	Foot care <input type="checkbox"/> Y <input type="checkbox"/> N	Complications <input type="checkbox"/> Y <input type="checkbox"/> N	Self-monitoring <input type="checkbox"/> Y <input type="checkbox"/> N
	Hypoglycaemia <input type="checkbox"/> Y <input type="checkbox"/> N	Self adjustment <input type="checkbox"/> Y <input type="checkbox"/> N	Member of a diabetic patient organisation <input type="checkbox"/> Y <input type="checkbox"/> N	

Measurements most recent value in the last 12 months	Weight _____ kg	Blood pressure _____ / _____ mmHg	Cholesterol _____
	Height _____ cm	BG _____	Creatinine _____
		HbA1 _____ %	Microalbum. _____
		HbA1c _____ %	Proteinuria _____
			HDL-Chol _____
			Triglycerides _____
			fasting <input type="checkbox"/> Y <input type="checkbox"/> N

ST.VINCENT TARGETS	Blindness <input type="checkbox"/> Y <input type="checkbox"/> N	IF YES: occurred last 12 months <input type="checkbox"/> Y <input type="checkbox"/> N	End-stage renal failure <input type="checkbox"/> Y <input type="checkbox"/> N	IF YES: occurred last 12 months <input type="checkbox"/> Y <input type="checkbox"/> N
	MI/CABG/Angioplasty <input type="checkbox"/> Y <input type="checkbox"/> N	IF YES: occurred last 12 months <input type="checkbox"/> Y <input type="checkbox"/> N	Leg amput. above ankle <input type="checkbox"/> Y <input type="checkbox"/> N	IF YES: occurred last 12 months <input type="checkbox"/> Y <input type="checkbox"/> N
	Cerebral stroke <input type="checkbox"/> Y <input type="checkbox"/> N	IF YES: occurred last 12 months <input type="checkbox"/> Y <input type="checkbox"/> N	Leg amput. below ankle <input type="checkbox"/> Y <input type="checkbox"/> N	IF YES: occurred last 12 months <input type="checkbox"/> Y <input type="checkbox"/> N

Symptoms within the last 12 months	Postural hypotension <input type="checkbox"/> Y <input type="checkbox"/> N	Anginal chest pain <input type="checkbox"/> Y <input type="checkbox"/> N	Peripheral neuropathy <input type="checkbox"/> Y <input type="checkbox"/> N	Leg claudication <input type="checkbox"/> Y <input type="checkbox"/> N
---	--	--	---	--

Examinations	EYES	Examined last 12 months	Y	N		FEET	Examined last 12 months	Y	N		
			L	R			L	R			
		Photocoagulation last 12 months	Y	N	Y	N	Normal vibration sensitivity	Y	N	Y	N
		Cataract	Y	N	Y	N	Normal pin prick sensitivity	Y	N	Y	N
		Retina seen	Y	N	Y	N	Foot pulses present	Y	N	Y	N
		IF YES: Maculopathy	Y	N	Y	N					
		Retinopathy	Y	N	Y	N	Healed ulcer	Y	N	Y	N
		IF Rp.: Non-proliferative Rp.	Y	N	Y	N	Acute ulcer/gangrene	Y	N	Y	N
		Preproliferative Rp.	Y	N	Y	N	Bypass/angioplasty	Y	N	Y	N
		Proliferative Rp.	Y	N	Y	N					
	Advanced diab. eye disease	Y	N	Y	N						
	Visual acuity: L: _____										
	R: _____										

Quality of Life/ Emergencies	Hypoglycaemia (no./yr) _____	Hyperglycaemia (no./yr) _____	Sick leave (d/yr) _____	Hospital days (d/yr) _____
-------------------------------------	------------------------------	-------------------------------	-------------------------	----------------------------

Management	Diet only	up to now	from now on	up to now	from now on
	Biguanides	since 1 9	Y N Y N	No. of Insulin injections/day	_____
	Sulphonylureas	since 1 9	Y N Y N	Insulin-pump	Y N Y N
	Glucosidase inhibit.	since 1 9	Y N Y N	Other treatment	Y N Y N

Additional Treatment	Hypertension	Cardiac failure	Isch. heart dis.	Dyslipidaemia	Nephropathy	Neuropathy	Other
	Y N Y N	Y N Y N	Y N Y N	Y N Y N	Y N Y N	Y N Y N	Y N Y N

Physician: (optional) _____	Signature Physician: _____	Date: _____
-----------------------------	----------------------------	-------------

© Diabcare Munich 11/9

Figure 1. DIABCARE dataset BIS and standard data definitions.

To develop BSTD register, it was necessary to take into account the existing standardized data sets such as DIABCARE^{10,12,14}. This has been the best solution in order to speak the same language in terms of diabetes dataset in Black Sea region¹⁵. By using a common dataset in BSTD it was not necessary to spend a lot of time and financial resources to integrate different and heterogeneous information about diabetes coming from different and highly heterogeneous sources for retrospective and prospective clinical data analysis in 12 countries in Black Sea area. Further, DIABCARE dataset has been created a bridge between West countries and East countries in Europe in diabetes care quality assessment and in the field of diabetes research. Finally, DIABCARE data set was adopted in developing the our BSTD system^{16,17}. As is shown in Figure 1, DIABCARE data set encompasses a broad range of diabetes variables that reflect both patient health status and healthcare data collection process. In addition, the WHO in Geneva in collaboration with the CDC in Atlanta, USA designed and implemented free software DIABCARE Epi Info to collect data and to produce statistical analysis graphs, charts and tables (as an alternative to the Fax/scanning solution¹²). Epi Info allows data to be entered directly into a computer in a user-friendly manner.

The DIABCARE data set BIS has been coherently structured that it is easily to register data on it. Diabetes care items are very well identified to enable consistent data capture and subsequent analysis. Over 50 process and outcome variables related to the diabetes care can be collected into DIABCARE BIS. There are comprehensive quantitative data items (variables) based on the measurements (*e.g.* HbA1c, BMI, BP, Creatinine, Microalbuminuria, etc., most recent value in the last 12 months) and qualitative data items (*e.g.* smoking, alcohol, etc. based on answers Yes/No). The BIS data set form of DIABCARE (a page A4 size), as shown in Figure 1, was clearly designed to make very well identified and the logical data separation.

MAIN MENU OF THE SYSTEM

Figure 2 displays the main menu with the screenshot of the main functions (Main Menu) of the system with the initial installation and administrative configuration displayed. Administrative access to the diabetes registry BSTD is limited to one physician which has the role of the system administrator. The system administrator function

(left column) is used to assigns the access rights to the Non Patients (clinicians) and Users (recorders) of the BSTD registry system. The level of access rights are filtered and protected by a user ID and password because specific measures were taken to ensure the confidentiality and integrity of the patients' data in our EHRs system. The content of this screenshot varies depending on the moment relative to the system initial installation and configuration. In Figure 2 it is displayed after ends the configuration process which is created and issued by the administrator and the administration functions were activated.

The Main Menu screen with the Patient Records functions activated is displayed for the first start of the BSTD registry system after the administration configuration process. The system has a number of individual application/functions being serviced by a layer database of relational tables of the relational database management system (RDBMS) that stores patient's details, clinical measurements, doctors and users' information – the persons involved in the direct or indirect provision of healthcare services to an individual or to patients' population.

The functional framework refers to the screenshot of the main menu of the BSTD system and consists of five major functions: "System Administration", "Patient Records", "Reports and Statistics", "Graphs" and "Clinical Protocols" as explained below. It is good to mention that ethical or legal issues with medical research *e.g.* on human embryos or fetus or issues with research on animals do not apply to the BSTD system both for either clinical practice implementation or medical research.

- **"System Administration"** function allows the update of the data about staff-members, users, health care facility, units for measurements, normal ranges for measurements, conversion rules for units.

- **"Patient Records"** function allows the registration of a new patient, the recording of a new sheet, the correction of a sheet, the visualization of a sheet, the recording of the data about the patient's death, the changing of the current user's password.

- **"Reports and Statistics"** function allows the printing of the selected sheets, the calculation both of the WHO DiabCare Aggregated Data (DAD) and of the Global DiabCare Aggregated Data.

- **"Graphs"** function allows the visualization/printing of various statistics in a graphical format.

Clinic levels level reporting can be visualized as tables and/or charts.

- “**Clinical Protocols**” function assists the physician with medical information about diabetes mellitus.

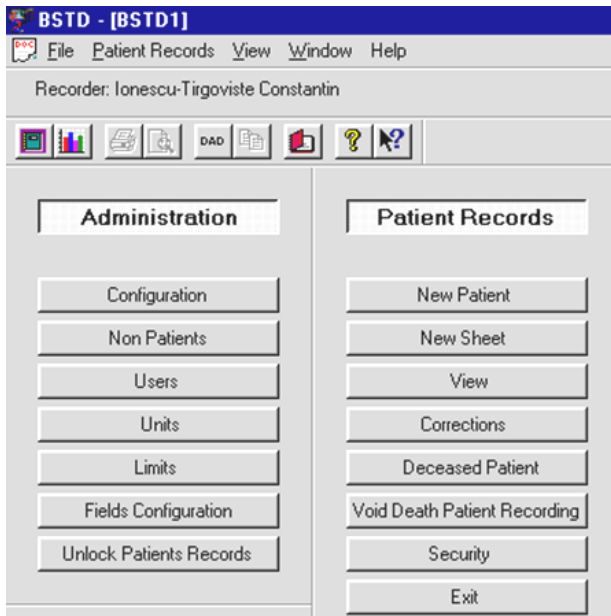

Figure 2. Main Menu Screen with the Administration functions activated.

As it is shown in the following screenshots over next sections of this chapter, the DIABCARE forms and data items are all out there so many clinicians are very familiar with the BSTD dataset.

The toolbar includes the following icons:



Reports – allows the activation of the “Reports and Statistics” function based on real data from the BSTD system patients’ electronic records in clinical practice. It is enabled when the user were assigned by the administrator the right to use the "Reports and Statistics" function. Data exported in CSV format can also be used for benchmarking exercise for comparative illustration of the diabetes prevention with screening methods¹⁸ and assess the diabetes care outcomes in the different local health care systems in the Black Sea area. Any patient’s personal data will be processed in compliance with Directive 2005/46 on the processing of personal data, well covered in the existing EU legislation. As a default, for privacy and security requirements, the data will be anonymised and files used for analysis of data will not include information that could be

used to identify specific individuals (e.g. name, initials nor birth date or their country of origin).



Graphs – allows the activation of the “Graphs” function. It is enabled to all legitimate users with assigned right to use the “Graphs” function.



Print – allows the printing of a report/graph. It is enabled when a report/graph is created.



Prints Preview – allows displaying report/graph on screen just as it will look when printed. It is enabled when a report/graph is created.



DAD – allows the activation of the “DIABCARE Aggregated Data” function. It is enabled when the user has the right to use the “DIABCARE Aggregated Data” function.



Copy – it is used for the “DIABCARE Aggregated Data” function in order to copy the selected data into the memory. It is enabled after the end of the analysis for DIABCARE Aggregated Data statistic.



Clinical Protocols – allows the activation of the “Clinical Protocols” function. It is enabled when the user has the right to use the “Clinical Protocols” function.



About – allows displaying program information, version number and copyright.



Help – allows obtaining additional information about the menu, button or field user click on.



Exit – allows to stop the BSTD system and to return to the WINDOWS system.

Security function allows the changing of the password for the current user. Access control is based on a password mechanism as is shown in Figure 3. Selection of access is restricted depending

on user rights based on a password mechanism. Passwords are stored in encrypted form in the system. BSTD system permits but not requires that the password is changed regularly by the user.

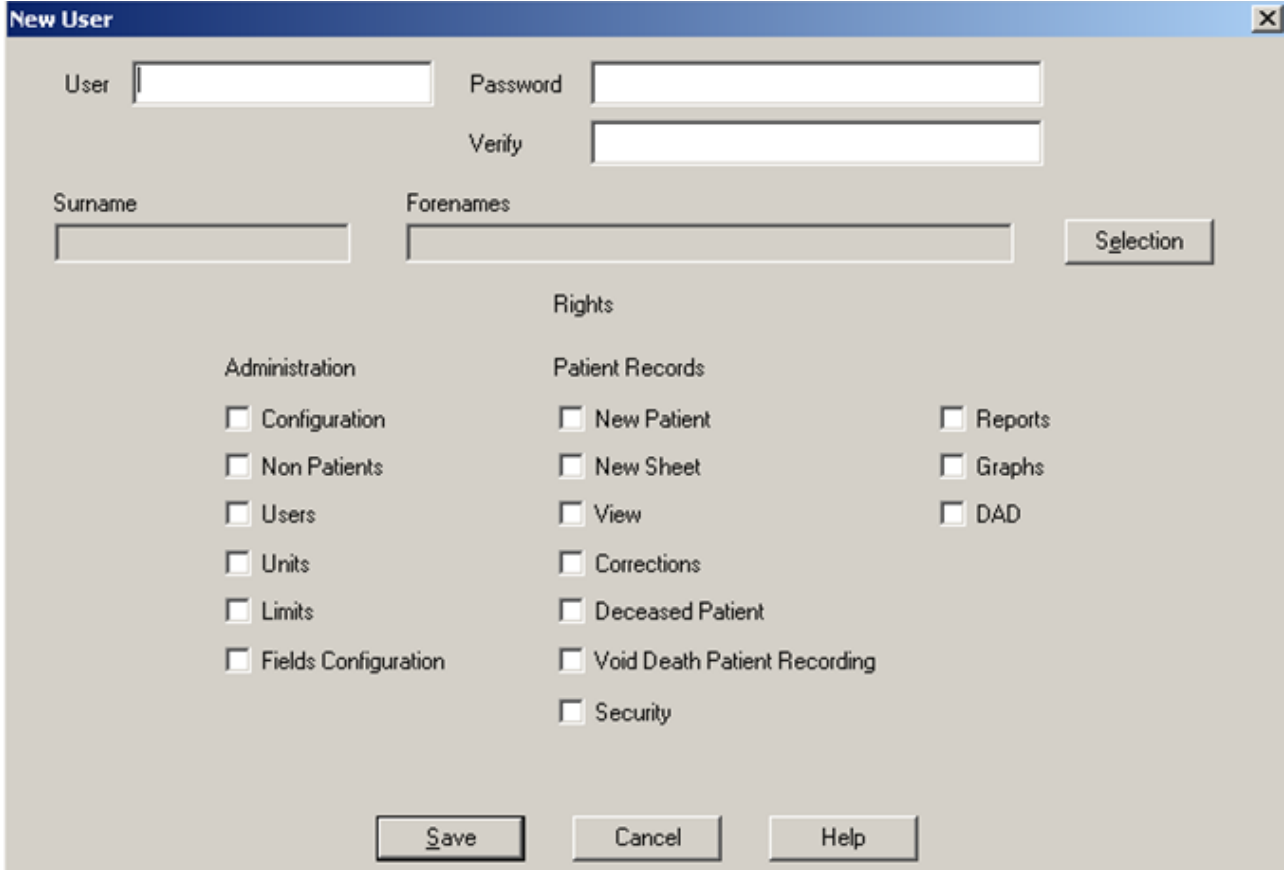

Figure 3. Selection of access which is restricted depending on user rights and based on a password mechanism.

MEASUREMENTS UNITS FUNCTION

In this module, the measurement units' configurations for the main components of quantity parameters of our EHR system are described. Parameters that are significant in a real-world clinical scenario for the measurement section of the BSTD system based on DIABCARE basic information sheet *e.g.* laboratory test results such as hemoglobin A1c laboratory tests (the main blood glucose indicator for Diabetes), LDL cholesterol concentration (for Hyperlipidemia), etc. are mirrored in the measurement screen of the system as shown in Figure 4. The BMI (for Obesity) is calculated automatically by the system from weight and height parameters.

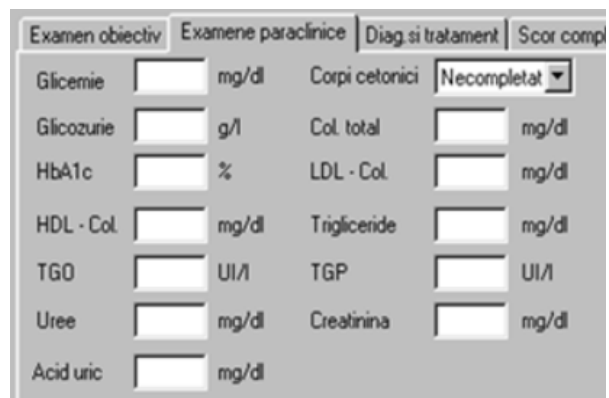

Figure 4. Measurement screen.

UML ACTIVITY DIAGRAM

Basic components of the GOMBSTD V2.0 object model of workflow descriptions and corresponding

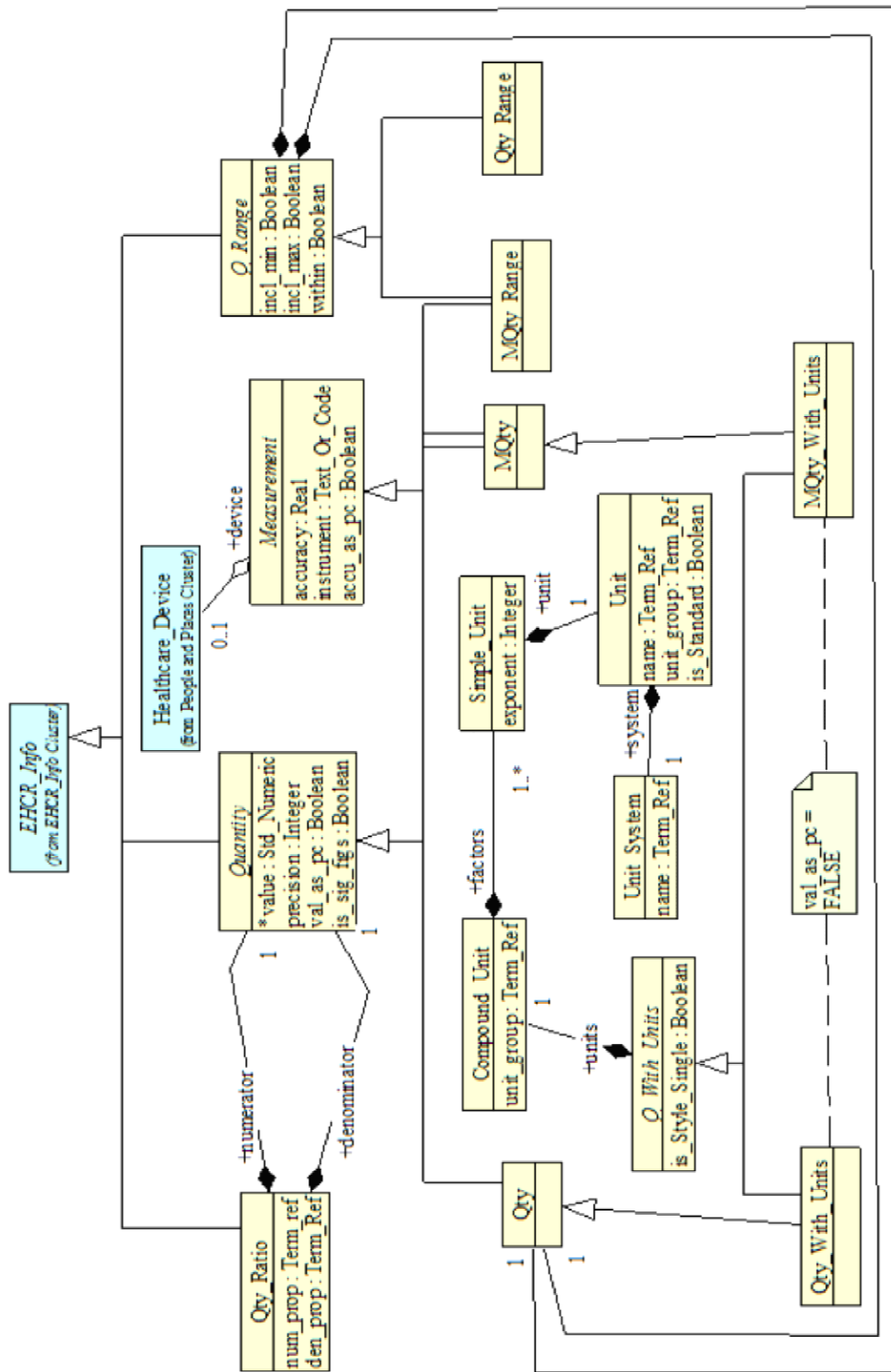

Figure 5. Detailed depiction of the UML class diagram with indicated components of the information objects and their attributes and their relationships for quantity cluster model.

data objects, associated data requirements and their corresponding attributes for quantity cluster are presented in Figure 5 as a Unified Modeling Language (UML). It is an information model in software engineering for representation of relationships, constraints, rules and operations to specify patient data collection and to describe functional and technical requirements for this module of our EHR system for collecting patient data quantitative data such as glycosylated haemoglobin (HbA1c), HDL-*col*, etc., which are clearly presented in Figure 4. It is good to mention here that our GOMBSTD V2.0 object model is based on CEN/ISO EN13606 European Standard standard^{19,20} communication extracts. The BSTD is based on ISO EN 13606 because ISO EN 13606 represents specifications for the exchange of EHR Extracts²¹. This standard has been developed by Technical Committee of the European Committee for Standardization (CEN).

Special attention was paid to avoid incorrect values of quantity parameters for each relevant laboratory test. So, in order to provide effective tools for units of measurements configuration, the “Units” function offers the following options:

- Recording of a new unit.
- Visualization of the selected unit.

The Unit Options Screen is shown in Figure 6. It allows the recording in the database of the information about a new unit of the selected type. It allows also the visualization of the information about the selected unit.

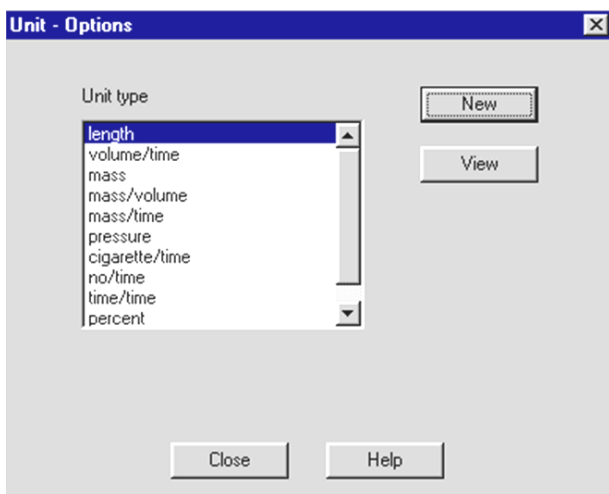

Figure 6. Unit options screen.

The “Limits” function allows the management of limits to reasonable value ranges for the numeric fields of the DIABCARE basic information sheet. The values entered in the numeric fields through the “Patient Records” functions are verified against these limits if any. If the value is not within these respective limits the system may trigger automatically a notification message (e.g. alert) which is displayed in a widow on the screen.

The “Limits” function offers the following options:

- Recording of new limits for the selected field.
- Correction of the limits for the selected field.

The screenshot for the Limits function (exemplified for microalbuminuria) is shown in Figure 7. It allows the definition of the characteristics (the default unit, precision, type of value, and lower and upper allowed limits) of the numeric fields.

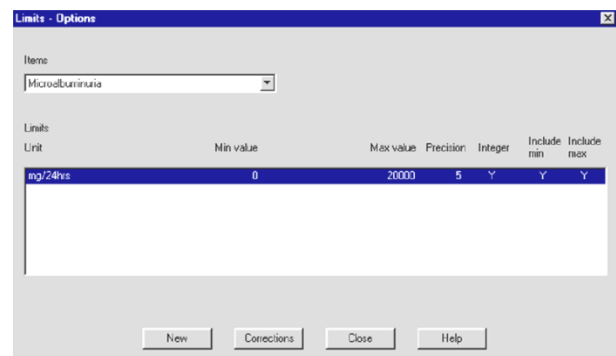

Figure 7. Limits for microalbuminuria.

The “Fields Configuration” function (Figure 8). It allows the definition of the characteristics (the default item, precision, value, min value and max value allowed) of the numeric fields of the measured parameters such as Wight, Height, HbA1C, etc.

The “Fields Configuration” function offers the following options:

- Visualization of the characteristics of the selected field,
- Correction of the characteristics of the selected field.

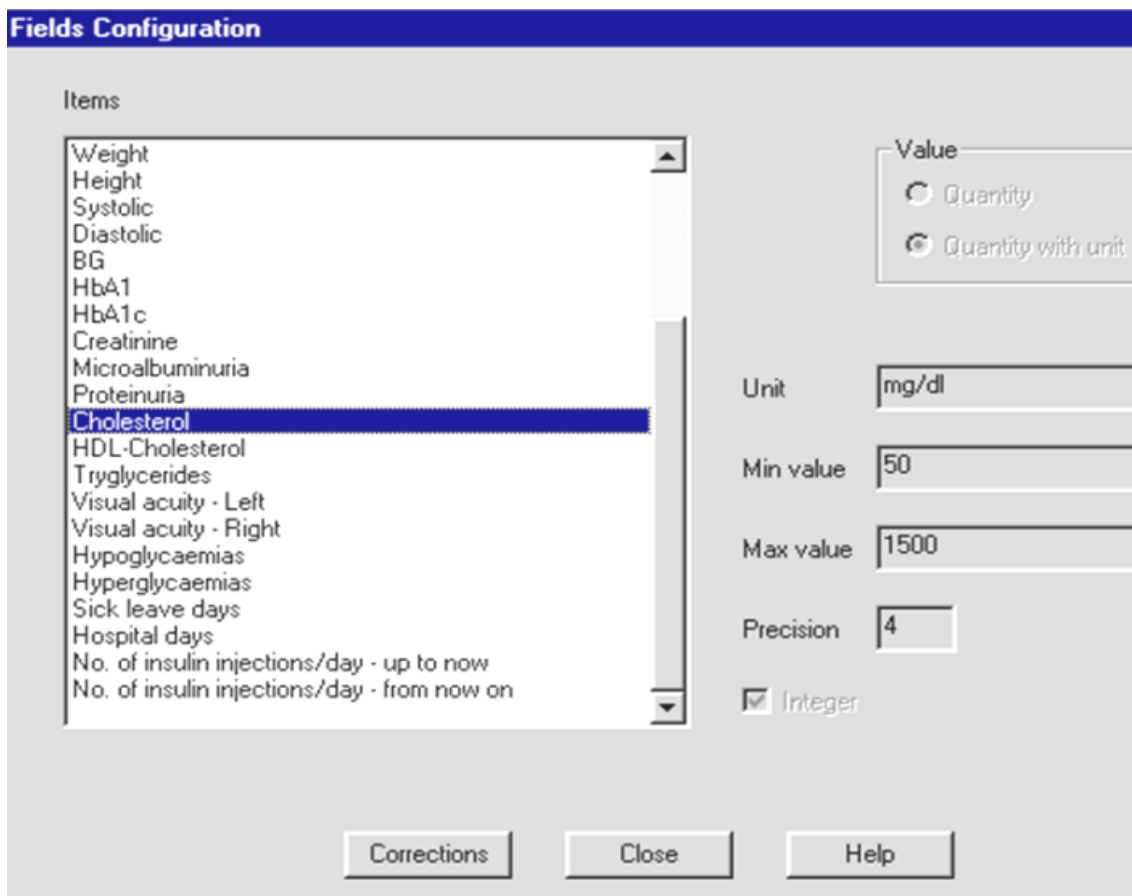

Figure 8. Fields configuration screenshot.

PATIENT RECORDS

The “Patient Records” function is the point where all information is recorded or is made available to healthcare professionals. The graphical user interface for adding new patients (new sheet) or editing (view an existing sheet) a current patient is user friendly. The “Patient Records” functions allow managing the patient EHR:

- New Patient – allows the registration of a new patient and the recording of his first sheet.
- New Sheet – allows the recording of a new sheet for an already registered patient.
- View – allows the visualisation of the selected sheet of the patient.
- Corrections – allows the correction of the last sheet of the patient.

- Deceased Patient – allows the recording of the data about the patient’s death.
- Void Death Patient Recording – allows the cancellation of the data about the patient’s death.

The BSTD system allows the recording of identification data for the patients that can be subsequently used in order to retrieve him in the database. Some of these data are mandatory. The following identification data can be recorded for a patient: name, additional names, date of birth, gender, patient number, additional identifiers, address, phone number, fax number, e-mail.

Most of these data are included on the *Patient “Identification Screen”* as shown in Figure 9. Other data are included on additional screen (Patient contact details) presented below in Figure 9.

The “New Patient” function, shown in Figures 4–15, performs two steps such as:

1. Registration of the patient.
2. Recording of the sheet.

After the activation of the “*New Patient*” function, the “*Patient Identification Screen*” is displayed (Figure 9). The identification of an existing patient is based on the patient’s identification number, allocated automatically by the system at the registration of the patient. The structure of the ID-Number is: the code of the country (2 characters) + the number of the centre (2 characters) + the local number of the patient in

the centre (8 characters). The codes of the countries are: RO – Romania, GR – Greece, MD – Moldavia, UA – Ukraine.

The ID-Number is used to uniquely identify the patient. If this number is not known, other data can be used for specifying search: surname, forenames, date of birth, gender. The BSTD system also allows the recording of the “*Patient Number*”, which represents the number of the patient used in the health care facility (hospital, diabetic centre, etc.). This is also used for specifying search of the patient in the BSTD system.

Figure 9. Patient identification screenshot for the “Registration of the Patient”.

EHRs DATA STREAMS FOR MACHINE LEARNING MODELS

We believe that longitudinal data collection through BSTD system, which is based on standardization protocols and methodology of data acquisition and processing, might have a very high impact in diabetes care because meanwhile to allow extracting new knowledge from multivariable clinical and health care in diabetes complex data, a

new technological paradigm has been developed in data analysis *e.g.* BIRO technology as it was detailed described elsewhere²². Moreover, currently in the big data era is using significantly advanced biotechnology based on prediction machine learning or “artificial intelligence” (with prediction accuracy of 94%, sensitivity of 93%, and specificity of 94% as is described in paper²³) and data mining methods through patients’ stratification and in-silico simulation. It is using genetic data and clinical

information generated from large Electronic Health Records²⁴. In this respect it is necessary to filter, enrich, and integrate data from external databases to improve machine learning predictive results to find new predictive results in diabetes care. Since a machine learning predictive system deals with incoming EHRs data streams as the primary source to integrate clinical data with new sources of omics data, the quality of data is of high importance because insufficient data quality will result in a low performance of the predictive system. Therefore, as has been described above the quality of data in BSTD diabetes register were to be assured through technical solutions which automatically checked the accuracy and completeness of data registered into the system.

REFERENCES

- Rasmussen A, Almdal T, Anker Nielsen A, *et al.* Decreasing incidence of foot ulcer among patients with type 1 and type 2 diabetes in the period 2001-2014. *Diabetes Res Clin Pract.* 2017; 130:221-228.
- Rosendo I, Santiago LM, Marques M. [Characteristics Associated with Uncontrolled Blood Pressure Among Portuguese Primary Care Patients with Type 2 Diabetes]. *Acta Med Port.* 2017; 30(3):197-204.
- Vrca Botica M, Carkaxhiu L, Kern J, *et al.* How to improve opportunistic screening by using EMRs and other data. The prevalence of undetected diabetes mellitus in target population in Croatia. *Public Health.* 2017;145:30-38.
- Göktaş O, Öz Gül Ö, Ertürk E. Changes in the management of type 2 diabetic patients in family medicine practices in the Bursa region. *Prim Care Diabetes.* 2017;11(2):178-183.
- Albu JB, Sohler N, Li R, *et al.* An Interrupted Time Series Analysis to Determine the Effect of an Electronic Health Record-Based Intervention on Appropriate Screening for Type 2 Diabetes in Urban Primary Care Clinics in New York City. *Diabetes Care.* 2017.
- Williams DR. Outcome indicators for diabetes services – what do we have and what do we need? *Community Med.* 1989;11(1):57-64.
- Diabetes care and research in Europe: the Saint Vincent declaration. *Diabet Med.* 1990;7(4):360.
- Attali JR. [DiabCare tools for the control of permanent improvement of the quality of care in diabetes]. *Diabete Metab.* 1993;19(5 Suppl):533-537.
- Cathelineau G. [Implementation of the Declaration of St. Vincent]. *Diabete Metab.* 1994;20(3 Pt 2):337-340.
- Gerlach K, Kaeding A, Kottmair S, Westphal D, Henning G, Piwernetz K. The implementation of a quality-net as a part of the European project DIABCARE Q-Net. *IEEE Trans Inf Technol Biomed.* 1998;2(2):98-104.
- Diabetes EAftSo. *Abstracts of the ... EASD annual meeting: Stockholm, Sweden, 12-16 September 1995.* Springer; 1995.
- Piwernetz K. DIABCARE Quality Network in Europe--a model for quality management in chronic diseases. *Int Clin Psychopharmacol.* 2001;16 Suppl 3:S5-13.
- de Beaufort CE, Reunanen A, Raleigh V, *et al.* European Union diabetes indicators: fact or fiction? *Eur J Public Health.* 2003;13(3 Suppl):51-54.
- Piwernetz K, Home PD, Snorgaard O, Antsiferov M, Staehr-Johansen K, Krans M. Monitoring the targets of the St Vincent Declaration and the implementation of quality management in diabetes care: the DIABCARE initiative. The DIABCARE Monitoring Group of the St Vincent Declaration Steering Committee. *Diabet Med.* 1993;10(4):371-377.
- Pruna S, IonescuTirgoviste C, Harris N. Tele-diab: Sending electronic patient records via e-mail. Paper presented at: DIABETOLOGIA1997.
- Pruna S, Dixon R, Harris ND. Black Sea TeleDiab: diabetes computer system with communication technology for Black Sea region. *IEEE Trans Inf Technol Biomed.* 1998;2(3):193-196.
- Pruna S, Harris ND, Dixon R, Laxminarayan S. Black Sea Tele Diab: Building an Information System for Management of Diabetes. IEEE EMBS INTERNATIONAL CONFERENCE ON INFORMATION TECHNOLOGY APPLICATIONS IN BIOMEDICINE; 2000; Arlington, VA, USA.
- Pimentel A, Carreiro AV, Ribeiro RT, Gamboa H. Screening diabetes mellitus 2 based on electronic health records using temporal features. *Health Informatics J.* 2016.
- Păun ID, Sauciu DG, Iosif NO, *et al.* Local EHR management based on openEHR and EN13606. *J Med Syst.* 2011;35(4):585-590.
- Muñoz A, Somolinos R, Pascual M, *et al.* Proof-of-concept design and development of an EN13606-based electronic health care record service. *J Am Med Inform Assoc.* 2007;14(1):118-129.
- Farfán Sedano FJ, Terrón Cuadrado M, Castellanos Clemente Y, Serrano Balazote P, Moner Cano D, Robles Viejo M. Patient Summary and medicines reconciliation: application of the ISO/CEN EN 13606 standard in clinical practice. *Stud Health Technol Inform.* 2011;166:189-196.
- Pruna S, Purtill C, Massi Benedetti M, *et al.* Screening for diabetic hypertension in newly diagnosed Type 2 diabetes using a new technology that carries out in minutes aggregated data analysis. *Proc Rom Acad, Series B, 2013.* 2013;2:2, p. 83-94, ISSN: 1454-8267.
- Barakat NH, Bradley AP, Barakat MN. Intelligible support vector machines for diagnosis of diabetes mellitus. *IEEE Trans Inf Technol Biomed.* 2010;14(4):1114-1120.
- Kavakiotis I, Tsave O, Salifoglou A, Maglaveras N, Vlahavas I, Chouvarda I. Machine Learning and Data Mining Methods in Diabetes Research. *Comput Struct Biotechnol J.* 2017;15:104-116.