

## NUMERICAL ANALYSIS OF FATIGUE FOR THE ASSESSMENT OF REMAINING SERVICE LIFE OF THE ERC 1400-30/7 BUCKET WHEEL EXCAVATOR

Sorin Mihai RADU<sup>1</sup>, Florin Dumitru POPESCU<sup>1</sup>, Andrei ANDRAȘ<sup>1</sup>, Iosif ANDRAȘ<sup>1</sup>, Ildiko BRÎNAȘ<sup>1</sup>, Florin VÂLCEANU<sup>2</sup>

<sup>1</sup> University of Petroșani, Department of Mechanical, Industrial, and Transport Engineering

<sup>2</sup> Popeci Utilaj Greu ltd. Craiova

Corresponding author: Sorin Mihai RADU, E-mail: rector@upet.ro

**Abstract:** This paper deals with the issue of the service life of the boom of a bucket wheel excavator (BWE) in a lignite open-pit, solved through a fatigue analysis with the aid of the SolidWorks application. To this purpose, the boom of the excavator, which is a spatial structure of a truss type, has been modelled in compliance with the geometrical and material conditions of the real system. For the beginning the linear dynamic time response was determined for a load produced by the excavation forces, with a global damping of 2%. The results of the analysis allowed for the determination of the deformations which occur and their frequency. Then the model underwent a static strain analysis with the established deformations to determine the stress generated by the excavation process, whose results cause the events which produce the fatigue. The frequency of the oscillations (vibrations) corroborated with the estimated or actual number of hours of service within a year determines the number of events that cause fatigue. Proceeding from these, the analysis of the fatigue status corresponding to a period of excavation of 10 to 30 years has been determined. Making the fatigue calculations with the aid of the SolidWorks application, it is possible to evaluate the degree of damage according to the period of exploitation, which determines the remaining service life of the BWE boom.

**Key words:** remaining service life, bucket wheel excavator, dynamic and static strain, fatigue, damage.

### 1. INTRODUCTION

Within the production of lignite, the main purposes represent the reduction of costs, environmental protection and the increase of the production capacity. One of the ways to achieve this is to continually improve the employed technology and equipment. Lignite extraction, usually achieved through open-pit mines requires, among other aspects, the guarantee of a safe and reliable operation of the basic equipment, amongst which the bucket wheel excavators are the most widely used.

Most bucket wheel excavators which operate in the open-pit mines in Central and Eastern Europe, as well as in Romania, display a service life between 15–40 years, some even longer. Although, during their operation, the bucket wheel excavators have been subject to modernization or/and rehabilitation in many stages, numerous severe damages occurred. As it was subsequently determined, the highest number of damages had been caused by the decrease in the resistance of main structural elements due to fatigue, or the overload caused by the appearance of rock inclusions or boulders with higher cutting resistance than the usually excavated material.

For these reasons, the estimation of the remaining life of the excavators which already have a considerable service life, is an issue of great importance in order to establish the maintenance policy which will ensure the replacement of the vulnerable components in due time, before the occurrence of major damage, respectively when the interval of the rehabilitation/modernization has to be set. In this field the study of fatigue can be an important instrument in the achievement of the targeted goals.

In this paper we will mainly focus on the boom of the excavator, the most vulnerable component of the load carrying structure. For this, we have used as model for the loads the dynamic time response of the excavator's boom under the action of specific excavation forces which form the basis for the occurrence of the events which cause fatigue, being transmitted from the bucket wheel to the shaft of the bucket wheel and from here to the structure of the boom [1].

The dynamic time response of the excavator's boom enables the evaluation of the deformation amplitude in the dominant direction, amplitude that will form the basis of a static analysis of the load carrying structure affected by this deformation. Also, the dynamic time response indicates the frequency of the oscillations (vibrations) which, corroborated with the estimated number of service hours (or number of hours of service in one year), will determine the number of events that cause fatigue. By calculating the fatigue with the specialized SolidWorks application, the degree of damage can be established in the end, according to the exploitation interval, which will determine the remaining service life of the most intensively used component, the boom.

## 2. THE CURRENT STATUS OF RESEARCH

The literature in the field approaches the issue of the fatigue resistance and the remaining service life of the metallic structures of the frame of truss type, which are subject to time variable and random strains, for instance metallic bridges, cranes, metallic structures for construction sites and other. The issue of the boom of the bucket wheel excavator is also examined in many research papers.

Some authors use for the bucket wheel excavator either loading diagrams estimated through theoretical data [2] or experimental measurements with strain gauges in certain points of the boom considered vulnerable [3, 4]. Other approaches refer particularly to the material the boom is made of, arguing that it determines the first failure, caused by the appearance or the increase of some fissures/cracks in the welded joints [5]. Structural failure was studied using experimental-numerical non-destructive techniques (like visual and magnetic-particle methods) in [6]. Authors of [7] point to a single component of the structure which is supposedly the most intensely strained by static or dynamic load. Studies also start from the construction of the plot of the magnitude of alternating stress versus the number of cycles until failure for a given material (S-N curve) on the basis of criteria which include the geometry and the characteristics of the vulnerable point under consideration [8–10]. The estimate of the deformations or the stress within the component considered vulnerable can be determined by either visual inspection or FEM for static load. The literature in the field refers more often to particular cases of strained elements [11–13] than structures which proves the difficulty and particularity of the fatigue phenomenon of the systems similar to the boom of the bucket wheel excavator [7, 14]. Establishing the number of cycles introduces another difficulty. Studies refer to structures which are different in terms of functionality but similar as structure and type of strain regarding variability, for example metallic bridges [15] and high capacity lattice crane [16].

Regarding the bucket wheel excavators the analysis of the fatigue is performed on those pieces of equipment which are near or have exceeded the normed service duration but cannot be replaced as they are essential in order to carry on the activity and their replacement requires a high financial effort. The method of the fatigue equivalent static load [17] is a method in which the variable load which causes the fatigue is replaced by quasi-static loads, whose response from the system constitutes the limit values of the variation domain of a fictional periodical load which is repeated a number of times during the service life of the construction. Authors of [18] perform a very detailed presentation of the problem of the residual life with special reference to cranes. Different fatigue curves are analysed for various frequencies of the load forces in [19] and the number of cycles until the fracture according to the type of components under discussion is established, between  $36.8 \times 10^6$  and  $7.370 \times 10^6$  cycles, considering more frequencies within the vibration spectrum. The analysis of the service life from the point of view of reliability and determination of the operation intervals between two defects is done in [20]. The integrity assessment is performed [21], emphasizing that although during the design process the service life is estimated through probabilistic methods which are based on the analogy with other machines and the expertise obtained during their operation with adjustments dictated by the differences between the pieces of equipment in question, the evaluation of the limit service life can be accomplished by continually monitoring the integrity correlated with the status of the operation conditions in order to establish the moment of improvement actions which will improve the structural integrity. In [22] authors present the techniques, equipment and analytical calculus methods of the service life of bucket wheel excavators, focusing on the importance of the accuracy of measurements in the control points. A combined method using Finite Element Analysis (FEA) and fracture mechanics is used in [23] to establish the residual service life of the most intensely strained part of the excavator's boom in order to determine the optimum moment of replacement. In [24] the results of tests

and analyses of complex dynamic loads carried out on a SchRs 650/5 × 24 Krupp bucket-wheel excavator are presented, as well as the assessment of the service life of vital welded structures of a bucket-wheel excavator boom subject to cyclic loading with a variable amplitude through the use of experimental tests carried out in order to determine operational strength and growth of a fatigue crack for one structural part. Structural integrity of a component of a ESRC 470 bucket-wheel excavator was assessed in [25] by performing a BEM analysis using the FRANC 3D software package for evaluation of the stress and strain state from the eye-plate of the tie rod.

### 3. MATERIALS AND METHODS

#### 3.1. Model and characteristics of the studied BWE

The examined model is an ERc 1400-30/7 type bucket wheel excavator which is the most frequently used in the exploitation of lignite in Romania.

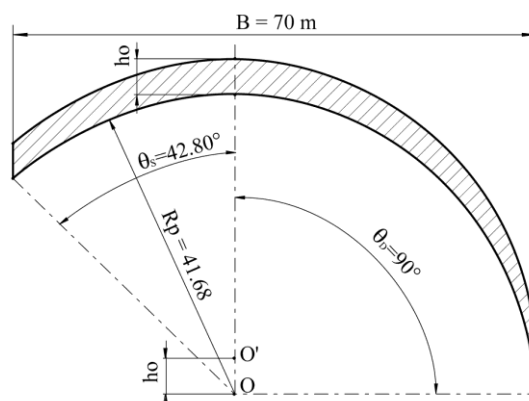

Fig. 1 – Geometric dimensions that characterize the volume of the cut.

The geometric dimensions which characterize the volume of the cut are presented in Fig. 1, where:  $B$  – the width of the block,  $R_p$  – pivoting radius,  $\theta_s$  – left pivoting angle,  $\theta_D$  – right pivoting angle,  $h_0$  – maximum thickness of the cut (advance step),  $D$  – cutting diameter of the bucket wheel (not drawn). These dimensions are dependant of the BWE type, its positioning in the face and the characteristics of the excavated face. For the ERc 1400-30/7 BWE the values of these cutting parameters are displayed in Table 1. Measurements in situ were performed [26] to determine the average cutting time of a terrace based on the characteristics shown in Table 1. The average time value is approximately 440 seconds.

Table 1

Cutting parameters of the studied BWE

No.	Characteristic	Symbol	M.U.	Value
1	Left / right pivoting angles	$\theta_s$	degrees	42.80
		$\theta_D$		90.00
2	Pivoting radius	$R_p$	m	41.68
3	Cutting diameter of the bucket wheel	$D$	m	11.5
4	Maximum thickness of the cut (advance step)	$h_0$	m	0.6
5	The width of the block	$B$	m	70

According to the position and functional role in the excavation process, the boom of the bucket wheel can be divided into 3 sections as marked in Fig. 2. In [1] a model was proposed for the boom of the ERc 1400-30/7 bucket wheel excavator, as a spatial, load-bearing structure that can be divided into the three aforementioned sections (Fig. 3): the joint section between the boom and the structure, which allows for both vertical and horizontal movement, the intermediate section on which the conveyor belt is mounted for the discharge of the excavated material, and the bucket wheel support section on which the drive mechanisms, as well as the boom hoist cable attachment device, are mounted.



Fig. 2 – The sections of the bucket wheel's boom.

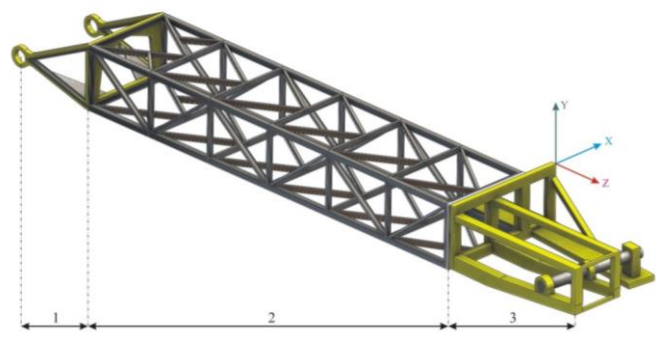

Fig. 3 – Sections of the BWE boom model [1].

The static loads applied on the boom [27] and the type of specific SolidWorks Simulation elements [28] required are presented in Table 2. The values in Table 2 are based on the manufacturer specifications. For the conveyor belt, the mass of the bulk material is included, the 25,000 kg considered being the total mass distributed on the boom. In order to simulate the conveyor and bulk material mass, it was defined as a Remote Load/Mass. The Remote Loads/Mass feature of SolidWorks Simulation allows us to assess the mass-and-inertia effects of a structural member on the whole structure without creating a finite element mesh or a model for such a part. The remote mass functionality is available for Static, Frequency, Linear dynamic, and Buckling studies. In the selected model for the fatigue analysis of the truss system we considered that the vibrations are caused only by the excavation forces.

Table 2

Static loads (mass forces) [27] and SolidWorks specific loads correspondence [28]

No.	External loads	Unit	Value	SolidWorks type of load [27]
1	Conveyor belt mounted on the boom	kg	25,000	Remote Loads/Mass
2	Kinematic chain of bucket wheel drive	kg	29,500	Distributed Mass
3	Virtual bucket wheel	kg	39,600	Part
4	Hoist cables of the boom	N/m	$2 \times 3.5 \times 10^7$	Spring

### 3.2. Preliminary considerations

In order to perform the fatigue analysis of the of the ERc 1400 excavator's boom, in the beginning we determined the linear dynamic time response to the excavation strain for a global damping of 2%. The obtained results of this analysis have enabled us to determine the deformations and their frequency. Section 2 of the model was subject to a static simulation in SolidWorks, where the deformations resulted from the dynamic time response analysis, were used as prescribed loads. The results of this static simulation represent the stress generated by the excavation process.

In the end we performed the analysis of the fatigue status corresponding to an excavation period of 10, 15, 20, 25 and 30 years respectively. The analysis of the linear dynamic time response of the model of the ERc 1400 excavator's boom was performed in the research paper [1]. The intermediate section 2 is a WELDMENT type with wire frame discretization [28, 29], and was created in SolidWorks application.

In order to simulate the excavation process, we used the Motion study menu of SolidWorks, by defining the cutting forces (tangent to the cutting direction) and those corresponding to the weight of the material (in direction of the gravity). After performing the simulation we obtained the total resultant force which produces the vibration within the structure of the boom. This force is variable in time and is caused by the excavation process (Fig. 4). The time of 26 seconds corresponds to two complete rotations of the bucket wheel, which means that a permanent regime of cutting has been achieved. The frequency of this force [1] is determined by the angular rotation speed of the bucket wheel and the number of cutting buckets and cutting-loading buckets installed on the bucket wheel. Fig. 5 displays the manner in which the total resultant forces has been applied to the model of the ERc 1400-30/7 excavator's boom.

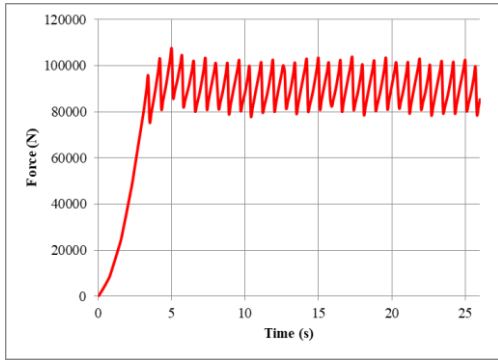

Fig. 4 – Force variation in time.

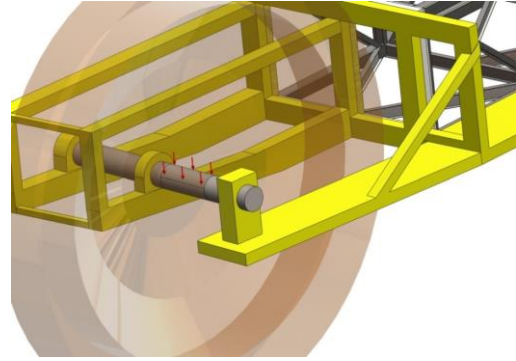

Fig. 5 – Applying the total resultant force to the bucket wheel excavator model.

As a result of the analysis of the linear dynamic time response, under permanent operating conditions, for the global damping of 2% [29] the accelerations and deformations for the X, Y and Z directions have been determined [1, 30]. Figure 6 shows the deformation for the Y (dominant) direction corresponding to the vertical plane. The figure also illustrates the necessary time required between cuts of consecutive slices. This graph is obtained by considering these deformations in the vertical (Y) direction on the exertion of force. The first time interval corresponds to the excavation of the first slice, then the positioning time is shown, and then the excavation of the second slice, with all times based on the parameters defined in Table 1. The average value of the deformation in this direction is of approximately 4.5 mm and the frequency of these deformations is of approximately 2 Hz.

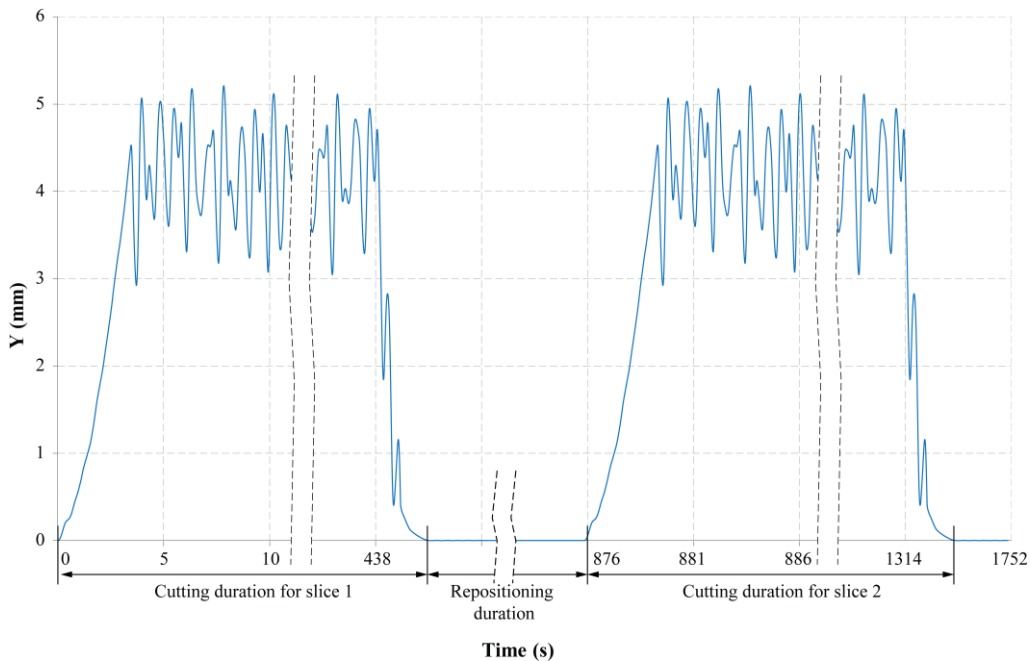

Fig. 6 – The deformation of the structure of the excavator's boom in a vertical plane.

### 3.3. The Fatigue Analysis of the ERc 1400 excavator's boom

The determination of the stress required for the analysis of fatigue has been performed by attributing the model of the ERc 1400 excavator's boom, a static strain determined by the average deformation of 4.5 mm obtained as a result of the dynamic time analysis [1]. We have considered the average deformation as these values are confirmed by in situ measurements [31, 32].

To analyse the resistance to fatigue of the truss structure of the excavator's boom, for the material which constitutes the truss, we adopted the S-N curve in Figure 7.

In literature there are two ways of drawing S-N diagrams: the FKM method which assesses the resistance to fatigue, developed at IMA Dresden, and based on the TGL 19340 Standard, and the North American Method, developed by various companies, applicable to structural elements of I, U type. The latter method was used in [33] to plot the S-N curve for characteristics of the material of the boom, for the number of cycles resulted from the operation time of the BWE and the stress measured on site through strain gauge measurement during the excavation process. Considering the results of the strain gauge measurements, the equation that approximates the variation of the S-N curve is  $S(N) = 2195.42 \cdot N^{-0.22657}$ . Based on this equation the author estimates the years of service until failure to approximately 28.4 years. For this reason, as the excavator we approach is of the same type, operating under similar circumstances, we have also adopted this curve for the SolidWorks analyses.

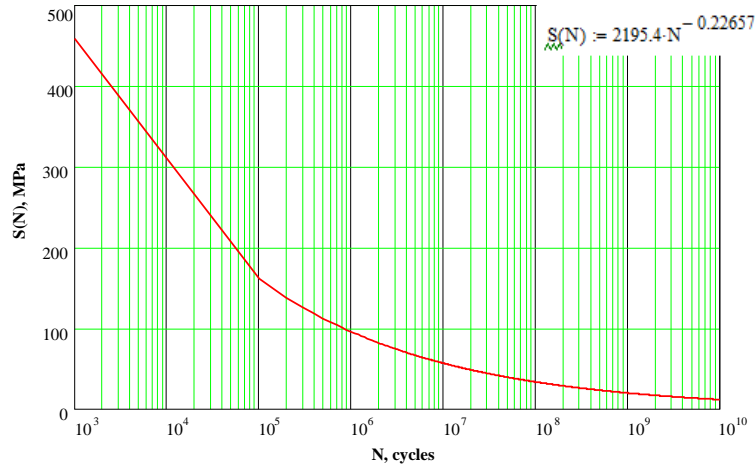

Fig. 7 – The fatigue curve of the material which constitutes the truss.

Figure 8 illustrates the variation of the stress resulted from the static analysis. One can note that the maximal resulted value is  $2.44 \times 10^8 \text{ N/m}^2$ . It is higher than the yield stress of the material which is  $2.068 \times 10^8 \text{ N/m}^2$ . It is expected that at the point where the calculated value of stress exceeds the yield stress of the material, the highest percentage of damage will occur.

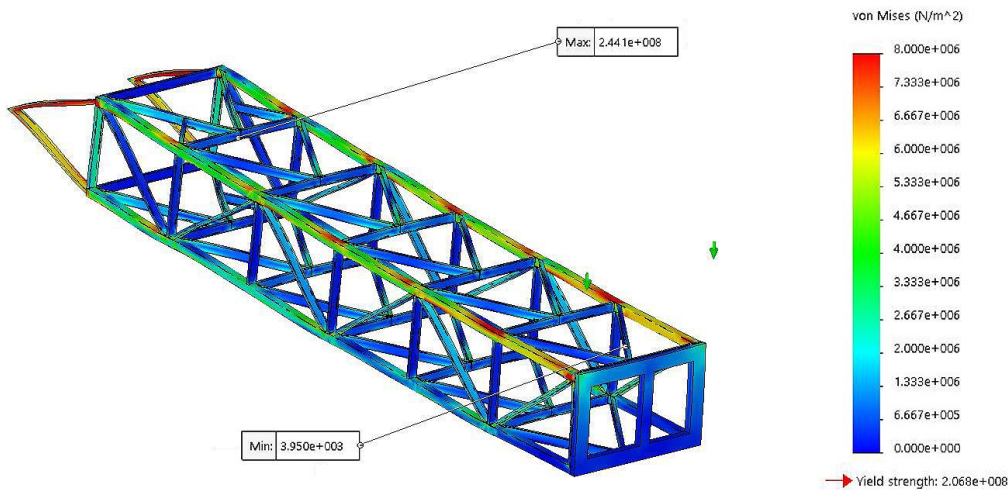

Fig. 8 – Von Mises stress for the structure of the boom treated as a solid.

Taking into account the working conditions of the BWE, during one year, the number of events that produce fatigue [30, 33] can be expressed as:

$$N = f \cdot 3600 \cdot t_{Ex} \cdot n_d \cdot 12 \cdot C_u, \quad (1)$$



where:  $f$  is the frequency of the deformations (4,5 mm) of the boom model, 2 Hz;  $t_{Ex}$  is the number of daily hours of excavation, 8 hours;  $n_d$  is the number of working days in a month, 22 days;  $C_u$  is the coefficient of intensive use, characteristic of this type of excavator, 0.5.

For these values the number of events calculated is:  $N_1 = 2 \cdot 3600 \cdot 8 \cdot 22 \cdot 12 \cdot 0.5 \approx 7,500,000$  events/year.

#### 4. RESULTS

In a preliminary evaluation, the fatigue study of the truss structure has been simulated in SolidWorks for 10 to 30 years of service, for every 5 years. The results of the fatigue study have been calculated by SolidWorks for the given structure for each of the time periods, for the corresponding number of events. The minimal and maximal damage rates for every simulated year are obtained as a damage percentage, and their locations are highlighted by the software. For the 30 year simulation, the results are shown in Figure 9. In a similar way, results for 10, 15, 20 and 25 years were obtained and values are presented in Table 3.

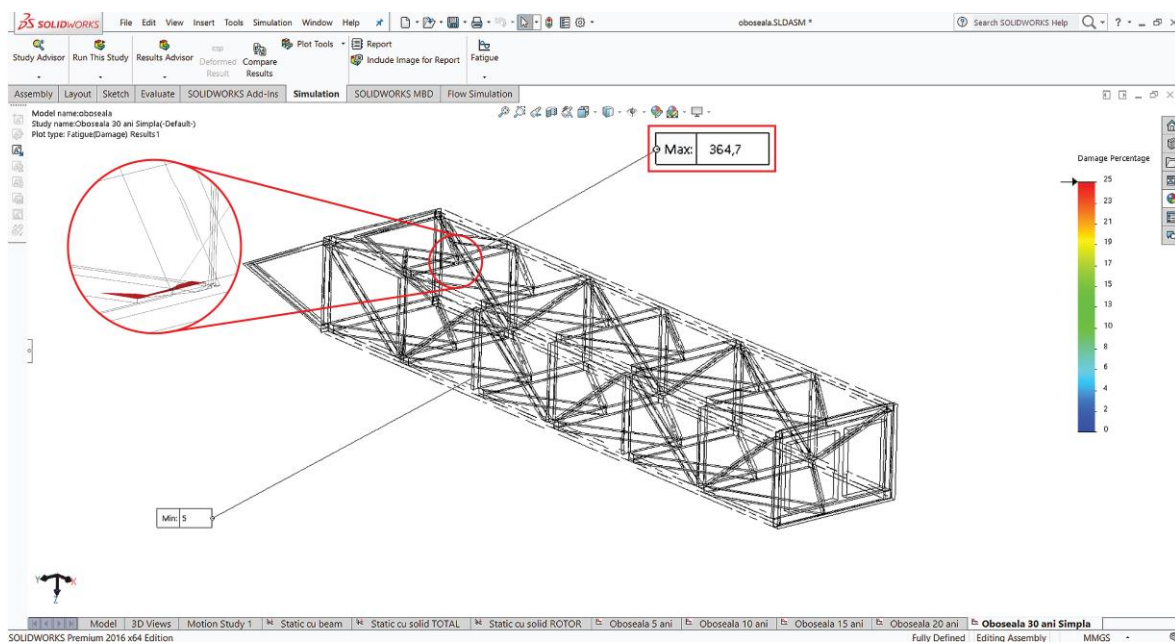

Fig. 9 – Highlighted positions of the minimal and maximal Damage at 30 years.

Table 3

Damage analysis results for 10 to 30 years of service, for every 5 years

No.	Analysed period of time (years)	Number of events ( $\times 10^6$ )	Damage (%)	
			Min.	Max.
1	10	75.0	2	13.5
2	15	112.0	2	19.7
3	20	150.0	3	26.3
4	25	187.5	4	32.8
5	30	225.0	5	364.7

Based on the damage values from Table 3, Fig. 10 shows the variation chart of the maximal damage variation for the entire structure according to the time interval expressed in years (in another scale the number of cycles).

Analysing the results of the damage rate variation, one can observe that after 25 years there is a sudden increase of the damage rate. This requires that the fatigue study should be simulated again, but for every year near the 25 year point. We obtained the minimal and maximal damage rate for this case, as presented in table 4. In a similar way, for every period of time in table 4, for the fatigue study run in SolidWorks, the points of minimal and maximum damage have been obtained.

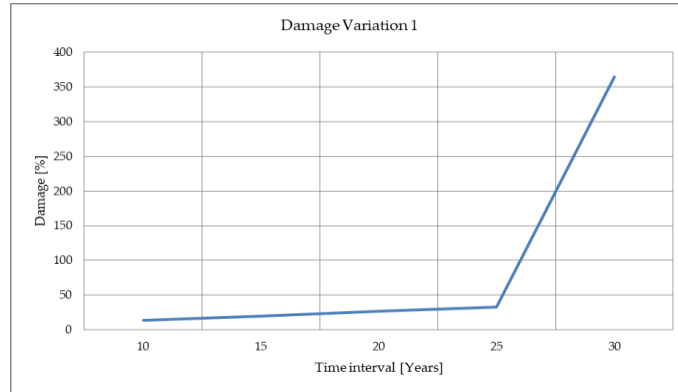

Fig. 10 – Preliminary evaluation of the damage variation chart.

Based on the damage values from table 4, Figure 11 shows the variation chart of the maximal damage variation for every year.

Table 4

Damage analysis results for 22 to 30 years of service, for every year

No.	Analysed period of time (years)	Number of events ( $\times 10^6$ )	Damage (%)	
			Min.	Max.
1	22	165.0	3	28.9
2	23	172.5	3	30.2
3	24	180.0	4	31.5
4	<b>25</b>	<b>187.5</b>	<b>4</b>	<b>32.8</b>
5	26	195.0	4	34.1
6	27	202.5	4	35.5
7	28	210.0	4	36.8
8	29	217.5	4	38.6
9	30	225.0	5	364.7

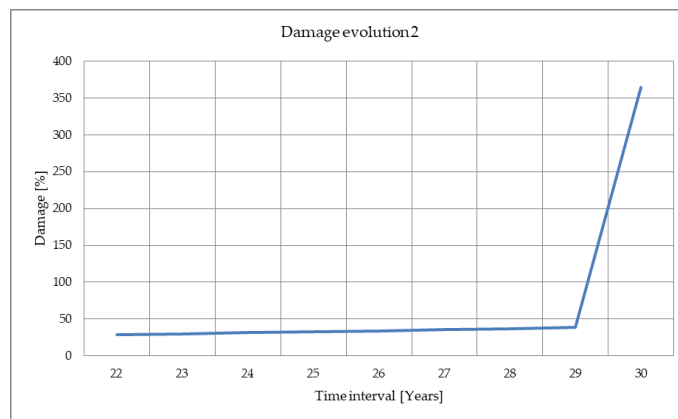

Fig. 11 – Damage variation chart.

The equation of the line passing through the points (29, 38.6) and (30, 364.7), representing the damage variation in the 29-30 years interval, is:

$$D = 326.1 \cdot T - 9418.3, \quad (2)$$

where:  $D$  is the damage in %;  $T$  is the time expressed in years.

To determine the moment at which the damage becomes 100%, this equation becomes:

$$T_{100} = \frac{D + 9418.3}{326.1} = \frac{100 + 9418.3}{326.1} \quad (3)$$

The result is  $T_{100} = 29.18$  years, corresponding to approximately  $219 \times 10^6$  events. The value is close to the one obtained in [33] of 28.4 years, which validates the simulation.



## 5. CONCLUSIONS

The analysis of fatigue of the truss structure of the wheel excavator represents a continuation of the authors' concerns, of simulation and modelling of the excavation mining installations. The virtual model of the boom used in this study has been created and presented by the authors in [1], where a study was performed of the dynamic state of the time response under the action of the excavation forces and the comparison of the obtained results with the measurements performed on site have validated the model. The fatigue curve used in the research was determined by laboratory tests conducted on samples, strain gauge measurements and calculations based on standards and normative [33].

The study of fatigue was performed in the SolidWorks application. We used the average deformation of the dynamic time response under the action of excavation forces as a static strain applied to the ends of the truss structures of the bucket wheel, the model being approached as a solid. Thus we determined the von Mises stresses, which has shown that for the joint area between the second stanchion and the corresponding wind bracings in the superior area of the truss structure, it displays a value which is superior to the yield stress.

The effective study of fatigue has been simulated for time intervals of 10, 15, 20, 25 and 30 years. For the 22 to 30 years interval, determinations were simulated for every year. We considered that the event which causes the strain is generated by the excavation force and its frequency is the frequency of the amplitudes of oscillations which resulted from the dynamic time response. This was determined by the number of strains corresponding to each analysed interval. The results of the fatigue study have highlighted, as expected, that the area in which the damage value is maximal corresponds to the interval of 30 years and is located where the von Mises stress reaches maximal values. The variation diagram of the maximal value of damage, according to the time interval, has shown that before the time interval of 29 years the maximal damage displays a slow linear increase between 13.5% and 38.6%. After the time interval of 29 years, the damage increase as calculated by SolidWorks simulation, is extremely high which indicates a severe fatigue of the material. Considering the variation between the time interval of 29 and 30 years as linear, the time when the damage value reaches 100% has been determined as 29.18 years.

The results obtained and presented in this paper are validated by the observations regarding the defects which occur during the operation of this type of excavator. First of all, it has been found that after a period of 22 years a series of deformations occur within the truss structure near the section of the joint of the boom and correspond to the joints between the stanchions and wind bracings in the superior part of the truss system.

The novelty of this fatigue study is the fact that it employs the results of a study [1] of the dynamic state time response of the boom under the action of excavation forces. The virtual model employed includes also the hoisting cables of the excavator's boom which have been simulated by two springs. Thus the frequency of the events which cause fatigue is 2 Hz, superior to the frequency of the excavation forces, given by the number of buckets and the speed of the bucket wheel, with the value of 1.25 Hz. This aspect determines, for a certain analysis interval, and under the same exploitation circumstances, a higher number of events that cause fatigue.

The performed analysis and the method based on the use of a virtual model of the truss structure of the excavator allow for an overall picture of the excavator's boom from the point of view of its fatigue. These can also be applied to other types of bucket wheel excavators, representing a useful predictive instrument of the fatigue state within the truss structure. It also provides support in the design of this type of installations in particular but also other installations which include trusses and are susceptible to vibrations.

## REFERENCES

1. F.D. POPESCU, S.M. RADU, K. KOTWICA, A. ANDRAȘ, I. KERTESZ (BRÎNAȘ), *Simulation of the time response of the ERc 1400-30/7 bucket wheel excavator's boom during the excavation process*, Sustainability, **11**, p. 4357, 2019.
2. S. BOŠNJAK, N. ZRNIĆ, D. OGUAMANAM, *On the dynamic modeling of bucket wheel excavators*, FME Transactions, **34**, 4, pp. 220-226, 2006.
3. M. RISTEIU, R. DOBRA, I. ANDRAS, M. ROVENTA, A. LORINCZ, *Investigation of bucket wheel excavator lattice structure internal stress in harsh environment through a remote measurement system*, IOP Conf. Ser.: Mater. Sci. Eng., **209**, p. 012065, 2017, DOI: 10.1088/1757-899X/209/1/012065.
4. A.D. BRKIĆ, T. MANESKI, D. IGNJATOVIĆ, P.D. JOVANČIĆ, V.K. SPASOJEVIĆ BRKIĆ, *Diagnostics of bucket wheel excavator discharge boom dynamic performance and its reconstruction*, Eksploat. Niezawodn., **16**, 2, pp. 188-197, 2014.

5. M. ARSIĆ, S. BOŠNJAK, N. ZRNIC, A. SEDMAK, N. GNJATOVIĆ, *Bucket wheel failure caused by residual stresses in welded joints*, Eng. Fail. Anal. **18**, 2, pp. 700-712, 2011, DOI: 10.1016/j.engfailanal.2010.11.009.
6. J. ANDRUSZKO, P. MOCZKO, D. PIETRUSIAK, G. PRZYBYŁEK, E. RUSIŃSKI, *Analysis of the causes of fatigue cracks in the carrying structure of the bucket wheel in the SchRs4600 excavator using experimental-numerical techniques*, In: CAE 2018 (eds. E. Rusiński, D. Pietrusiak), Lect. Notes Mech. Eng., Springer, Cham, pp. 15-28, 2019, DOI: 10.1007/978-3-030-04975-1\_3.
7. S.M. BOŠNJAK, M.A. ARSIĆ, N.B. GNJATOVIĆ, I.L. MILENOVIĆ, D.M. ARSIĆ, *Failure of the bucket wheel excavator buckets*, Eng. Fail. Anal., **84**, pp. 247-261, 2018, DOI: 10.1016/j.engfailanal.2017.11.017.
8. D. DANICIC, S. SEDMAK, D. IGNJATOVIC, S. MITROVIC, *Bucket wheel excavator damage by fatigue fracture. Case Study*. Proc. Mat. Sci., **3**, pp. 1723-1728, 2014, DOI: 10.1016/j.mspro.2014.06.278.
9. S. PAPANIKOLAOU, D. FASNAKIS, A. MAROPOULOS, D. GIAGOPOULOS, S. MAROPOULOS, T. THEODOULIDIS, *Non-destructive testing of fatigue specimens of a welded bucket wheel excavator*, 1st International Conference on Welding & NDT, Athens, Greece, 2018.
10. H. NAKAMURA, S. NISHIJIMA, A. OHTA, Y. MAEDA, K. UCHINO, T. KOHNO, K. TOYOMASU, I. SOYA, *A method for obtaining conservative S-N data for welded structures*, J. Test. Eval., **16**, 3, pp. 280-285, 1988, DOI: 10.1520/JTE10379J.
11. M. SAVKOVIĆ, M. GAŠIĆ, M. ARSIĆ, R. PETROVIĆ, *Analysis of the axle fracture of the bucket wheel excavator*, Eng. Fail. Anal., **18**, 1, pp. 433-441, 2011, DOI: 10.1016/j.engfailanal.2010.09.031.
12. E. RUSIŃSKI, J. CZMOCHOWSKI, A. ILUK, M. KOWALCZYK, *An analysis of the causes of a BWE counterweight boom support fracture*. Eng. Fail. Anal., **17**, 1, pp. 179-191, 2011, DOI: 10.1016/j.engfailanal.2009.06.001.
13. E. RUSIŃSKI, P. HARNATKIEWICZ, M. KOWALCZYK, P. MOCZKO, *Examination of the causes of a bucket wheel fracture in a bucket wheel excavator*, Eng. Fail. Anal., **17**, 6, pp. 1300-1312, 2010.
14. H. AGERSKOV, *Fatigue in steel structures under random loading*, J. Constr. Steel Res., **53**, 3, pp. 283-305, 2000.
15. C.S. WANG, B.T. YEN, H.T. LI, L. DUAN, *Fatigue life evaluation of in-service steel bridges by using bi-linear SN curves*, Adv. Steel Constr., **11**, 3, pp. 269-282, 2015, DOI: 10.18057/IJASC.2015.11.3.2.
16. Y. TINGJUN, W. XIANMIN, L. YONG, *Study on fatigue life assessment of offshore platform lattice crane in service*, Int. J. Control Autom., **8**, 2, pp. 251-262, 2015, DOI: 10.14257/ijca.2015.8.2.25.
17. J. WANNENBURG, P.S. HEYNS, A.D. RAATH, *Application of a fatigue equivalent static load methodology for the numerical durability assessment of heavy vehicle structures*, Int. J. Fatigue, **31**, 10, pp. 1541-1549, 2009, DOI: 10.1016/j.ijfatigue.2009.04.020.
18. B. DEPALE, M. BENNEBACH, *Residual life of steel structures and equipment: problems and application to cranes.*, Mech. Ind., **20**, 8, pp. 802, 2019, DOI: 10.1051/meca/2019047.
19. Z. MARINKOVIĆ, G. PETROVIĆ, *Processing the lifetime of bucket wheel excavator parts in strip mine technologies*, Facta Univ., Ser. Mech. Eng., **2**, 1, pp. 109-124, 2004.
20. Ž. LAZAREVIĆ, I. ARANĐELOVIĆ, S. KIRIN, *The reliability of bucket wheel excavator-review of random mechanical failures*, Teh. Vjesn., **25**, 4, pp. 1259-1264, 2018.
21. D. POLOVINA, S. IVKOVIC, D. IGNJATOVIC, M. TANASIJEVIC, *Remaining operational capabilities evaluation of bucket wheel excavator by applying expert assessment method with empirical correction factor*, Struct. Integr. Life, **10**, 1, pp. 31-41, 2010.
22. J. ALENOWICZ, W. HUSS, *Fatigue life estimation in bucket-wheel excavators maintenance*, In: RESRB 2016 (eds. E. Rusiński, D. Pietrusiak), Lect. Notes Mech. Eng. Springer, Cham, pp. 9-17, 2016. DOI: 10.1007/978-3-319-50938-9\_2.
23. F. VÎLCEANU, C. IANCU, *One method for life time estimation of a bucket wheel machine for coal moving*, In: IOP Conf. Ser.: Mater. Sci. Eng., **147**, p. 012064, 2016, DOI: 10.1088/1757-899X/147/1/012064.
24. D. ARSIĆ, N. GNJATOVIĆ, S. SEDMAK, A. ARSIĆ, M. UHRICIK, *Integrity assessment and determination of residual fatigue life of vital parts of bucket-wheel excavator operating under dynamic loads*, Eng. Fail. Anal., **105**, pp. 182-195, 2019, DOI: 10.1016/j.engfailanal.2019.06.072.
25. A. CERNESCU, L. MARSAVINA, I. DUMITRU, *Structural integrity assessment for a component of the bucket-wheel excavator*, Int. J. Struct. Integr., **5**, p. 129-140, 2014.
26. F.D. POPESCU, S.M. RADU, A. ANDRAȘ, I. KERTÉSZ, *A grafo-numeric method of determination of the operation power of the rotor of ERc-1400 bucket wheel excavator using computer simulation in SolidWorks*, In: MATEC Web of Conferences, **290**, p. 04007, 2019, DOI: 10.1051/mateconf/201929004007.
27. ROMINEX S.A. Timișoara, *Excavatorul cu roată portuape ERc 1400 - 30/7 modernizat, instrucțiuni de exploatare, întreținere și reparații* (in Romanian), 2007.
28. P.M. KUROWSKI, *Engineering analysis with SOLIDWORKS® Simulation 2015*, SDC Publications, 2015.
29. P.M. KUROWSKI, *Vibration analysis with SOLIDWORKS® Simulation 2016*, SDC Publications, 2016.
30. I. KERTESZ (B.), *Contribuții la studiul echipamentelor miniere de excavare prin modelare și simulare în vederea îmbunătățirii performanțelor funcționale ale acestora* (in Romanian), Ph.D. Thesis, University of Petroșani, Romania, 2019.
31. M. LAZAR, I. ANDRAS, M. RISTEIU, I. PREDOIU, *In situ measurements regarding the BWE boom using accelerometers and strain gauges at BWEs operating in CEO open pits*, Górnictwo Odkrywkowe, **59**, 4, pp. 86-93, 2018.
32. F. VÎLCEANU, I. ANDRAȘ, M. LAZĂR, *Fatigue assessment of BWE boom members and joints in order to assess their remaining lifetime*, Górnictwo Odkrywkowe, **59**, 4, pp. 74-79, 2018.
33. V.F. VÎLCEANU, *Studiul duratei de viață pentru utilajele de extragere și depunere în depozite, utilizate în carierele din bazinul Olteniei* (in Romanian), Ph.D. Thesis, University of Petroșani, Romania, 2018.